

AC powered bicolor Fresnel LED with motorized zoom and wireless control

KOSMOS is the compact LED fresnel with built-in ballast, producing unprecedented output due to its VELVET light engine. High color reproduction (98 TLCI) for color skin tones. Smooth stepless dimming and flicker free operation up to 12000 fps. Any base white light from 2700 to 6500K can be set. Change the powerful light beam angle on air from 11° to 56° locally or remotely with no need to access the luminaire. A lightweight low-carbon aluminum body; KOSMOS has a resistant housing made in recycled aluminum which reduces our/your carbon footprint. A real "made to last" lighting fixture 100% manufactured in Barcelona.



1. 2x handles and security cable attachment
2. 2x XLR-5 DMX In & Out connector
3. 2x PowerCon In & Out through connectors
4. Antena
5. Digital display
6. 2x Rotary selector button
7. USB connector
8. LAN connector
9. Main power switch



SPECIFICATIONS	
OPTICAL SYSTEM	Motorized ZOOM Fresnel
LIGHT APERTURE	Borosilicate glass Fresnel lens 240mm / 14.6"
LIGHT ENGINE	35mm W+CW+Green VELVET ceramic COB
COLOUR TEMPERATURE	Continuously adjustable from 2700K to 6500K
GREEN MAGENTA	Continuously adjustable (full plusgreen to full minusgreen)
CONTROL COLOR MODES	CCT
LIGHT INTENSITY	Dimmable 0 to 100, smooth and flicker-free
LOCAL CONTROL	Rotary knob and display + 3200K / 5600K quick access + Mode selection buttons
WIRE CONTROL	DMX-RDM with XLR-5 In + LAN connectors
WIRELESS CONTROL	DMX-RDM with LumenRadio
TLCI INDEX	96 at 3197K and 98 at 5676K
PHOTOMETRICS	Beam angle 50°: 4225 lux / 393 fc at 3m / 10 feet — 1145 lux / 106 fc at 6m / 20 feet Beam angle 11°: 11065 lux / 1028 fc at 3m / 10 feet — 2760 lux / 256 fc at 6m / 20 feet
BEAM ANGLE	From 11° to 56°
DIMENSIONS (Without yoke)	290x583x176mm / 11.5x23x7 inches
WEIGHT	9.3 kg/ 20.5 lbs (fixture) 9.8 kg/ 22.6 lbs (fixture + yoke)
POWER DRAW	230W (0.9A at 220VAC — 1.8A at 110VAC)
POWER SUPPLY	96-260V AC XLR-3 IN connector
LED RATED LIFE	More than 50.000 hours
POWER CONNECTION	Neutrik PowerCon TRUE1 TOP In & Out connectors
OUTPUT FREQUENCY	Over 12,000 fps
OPERATION TEMPERATURE	From -20°C to +40°C
COOLING	Passive liquid cooling system into sealed 3D chamber with silent fan
PROTECTION	IP30, indoor or outdoor protected use
RIGGING OPTIONS	Aluminum yoke with 16mm baby receptacle combined with 28mm junior pin, pole operated yoke.
QUICK MOUNTING ACCESSORIES	Foldable SnapBag, foldable Snapgrid, Octa, Lantern, removable Barn doors, hard case,
CONSTRUCTION & FINISH	Fixture and yoke made of die-cast aluminum

WIRE VIEW

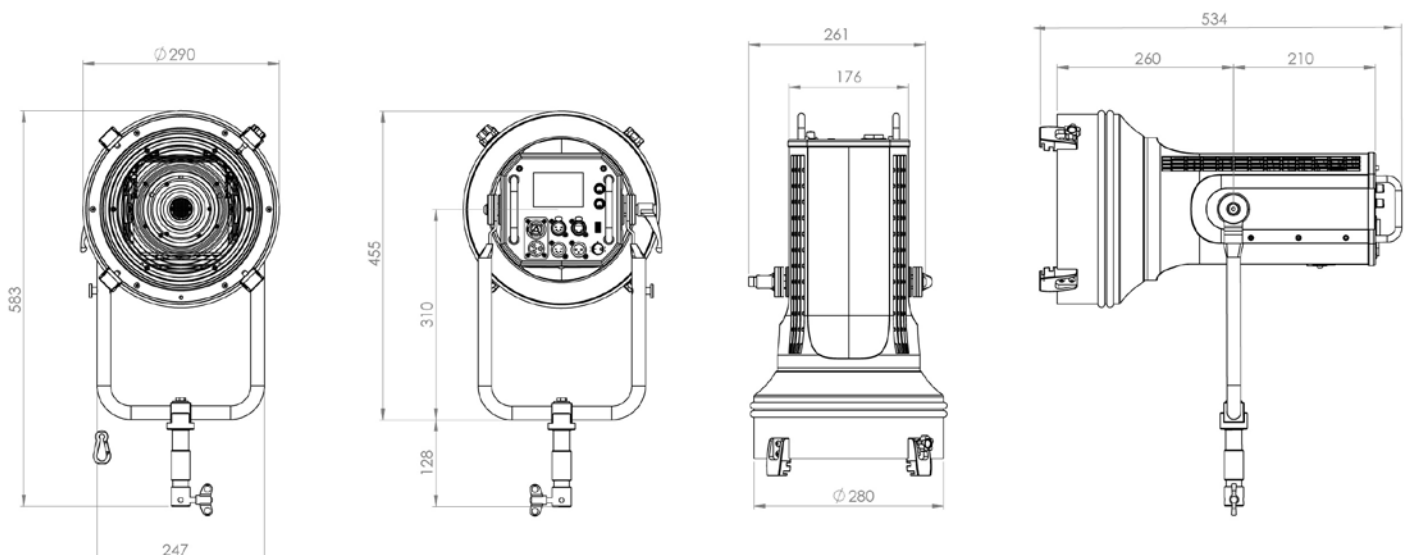

PHOTOMETRICS

